

5) TECHNICAL SPECIFICATIONS

	IRC2204	IRC2207	IRC2209
Image Sensor	1/4" Sony CCD	Sharp 1/3" CCD	Sony 1/3" CCD
Resolution	420 Lines	520 Lines	520 Lines
Lens	6.0 mm @ F2.0		
Effective Pixels	510(H) x 492(V)	768(H) x 494(V)	768(H) x 494(V)
Min. Illumination	0 LUX (LED on) / 1.0 LUX (LED off)		
Field of View	60° ± 5°		
Electric Shutter	1/60s - 1/10,000s		
Operating Temperature	-10°C ~ 45°C (14°F ~ 113°F)		
Operating Humidity	50%-80%		
LED Quantity	30 pcs (@ 5mm)		
IR Range	70 ft / 21 m (under optimal conditions)		
IP Rating	IP67		
Power Requirement	12V dc		
Current Consumption	370 mA	350 mA	370 mA

6) DIMENSIONS

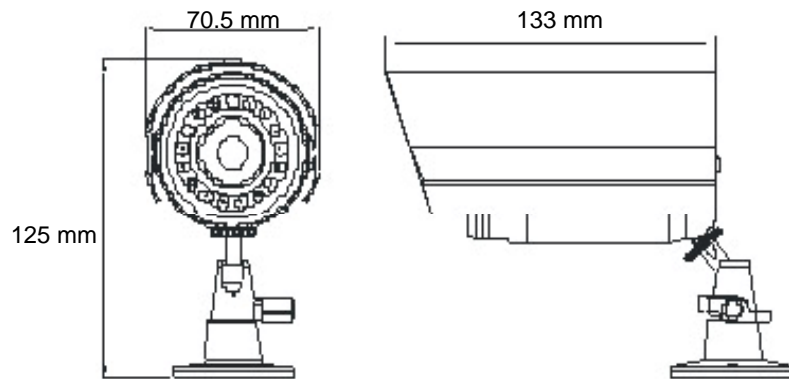

7) WARRANTY

IRES Technology warrants all of its products for one year, starting from the date of purchase. Please refer to the included Warranty card or go to www.IREStechology.com for more details. In no event shall IRES be liable for incidental, accidental or consequential damages arising from the use or inability to use its products.

Copyright © 2008 IRES Technology Corp.
Specifications are Subject to Change. E&OE

SETUP INSTRUCTIONS



IRC2200 Series

**Hi-Res Indoor / Outdoor Color Camera
with 30 LEDs**



For more information visit:

www.IREStechology.com

Thank you for purchasing the IRC2200 Series camera from IRES Technology. Please review the following instructions thoroughly before installing and connecting the camera.

1) CAMERA MODEL

Depending on the camera purchased, you received one of the following models:

- IRC2204 – 1/4" Sony CCD, 420 TV Lines
- IRC2207 – 1/3" Sharp CCD, 520 TV Lines
- IRC2209 – 1/3" Sony CCD, 520 TV Lines

2) FEATURES

- Hi-res image sensor provides outstanding picture quality
- 30 high-intensity LED's provide Night Vision of up to 70 ft
- Heavy-duty IP67 construction – ideal for outdoor use
- Picture automatically turns to B/W in low light conditions
- Easy to install with camera mounting kit included

3) CONTENTS

Please ensure that your package includes the following:

- IRC2200 Series Camera
- Mounting Bracket
- Mounting Screws
- Owner's Manual



Note: Power Adapter and Video/Power Cable are not supplied but can be purchased separately at www.IREStechnology.com

4) CAMERA INSTALLATION

- i** Before permanently mounting the camera, it is recommended that you first confirm its performance by connecting it to your DVR / Monitor, powering the unit and viewing the picture.
- a) Position the stand base to the wall or ceiling area where you want to install the camera. Drill 1 inch holes to align with the 3 screw-holes in the bracket and then secure it using the supplied screws and anchors.
 - b) Attach the camera to the supplied mounting bracket and tighten the swivel.
 - c) Connect the camera to a Video/Power extension cable [Male BNC / Male DC]. Cable is not included as standard but can be purchased through www.IREStechnology.com
 - d) Run the cable to a DVR or Monitor input and connect the BNC Video. Also connect a 12V DC Power Adapter - available online at www.IREStechnology.com

